

Figura 19. Estructura y símbolo del filtro

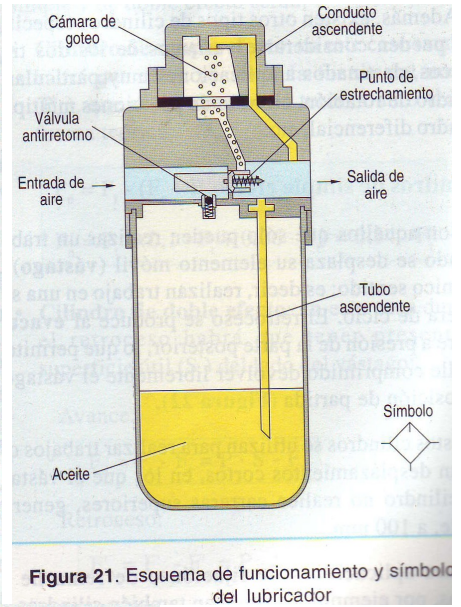

Figura 21. Esquema de funcionamiento y símbolo del lubricador

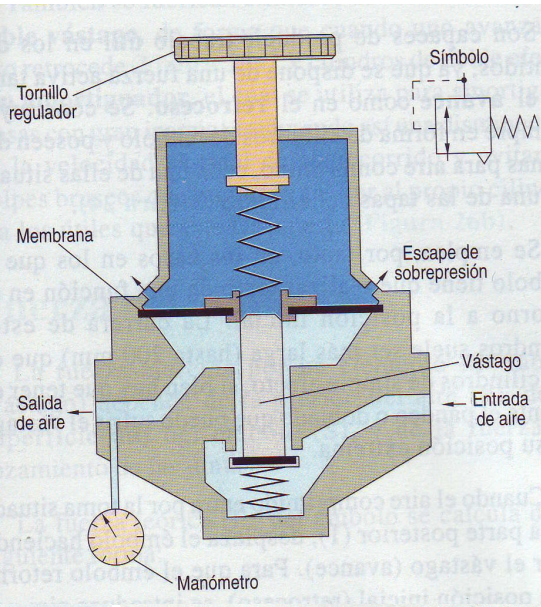
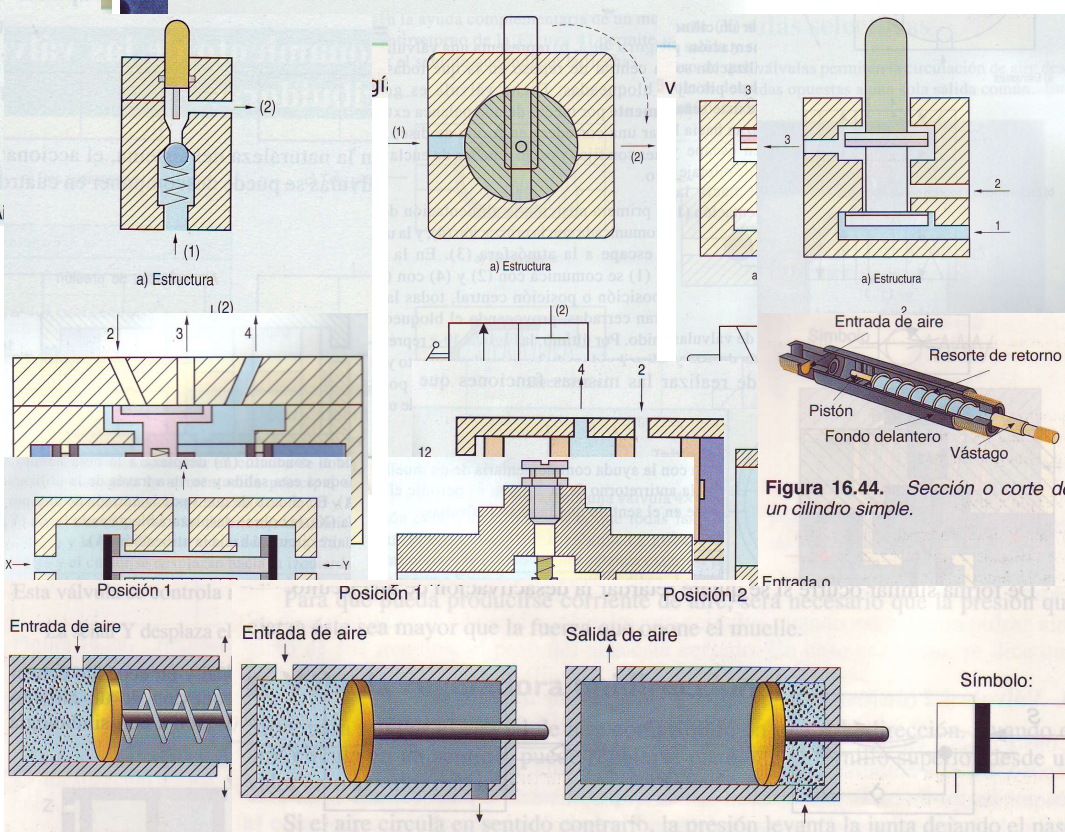
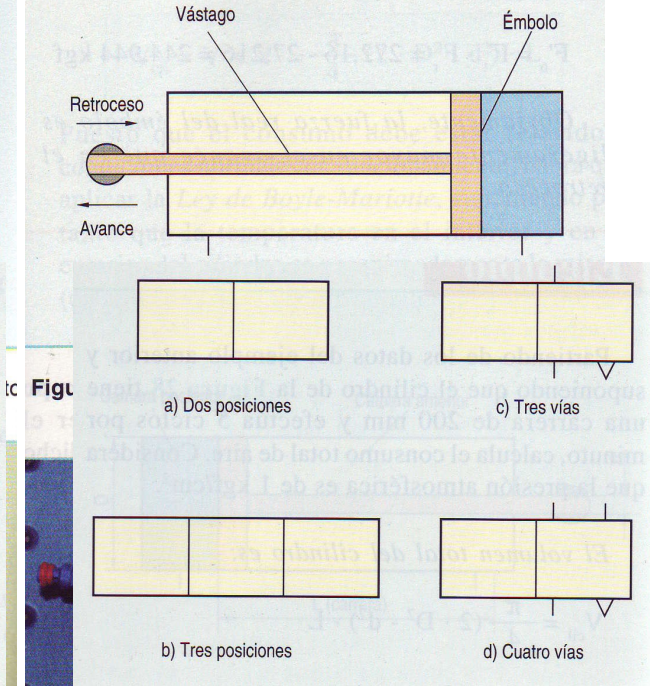
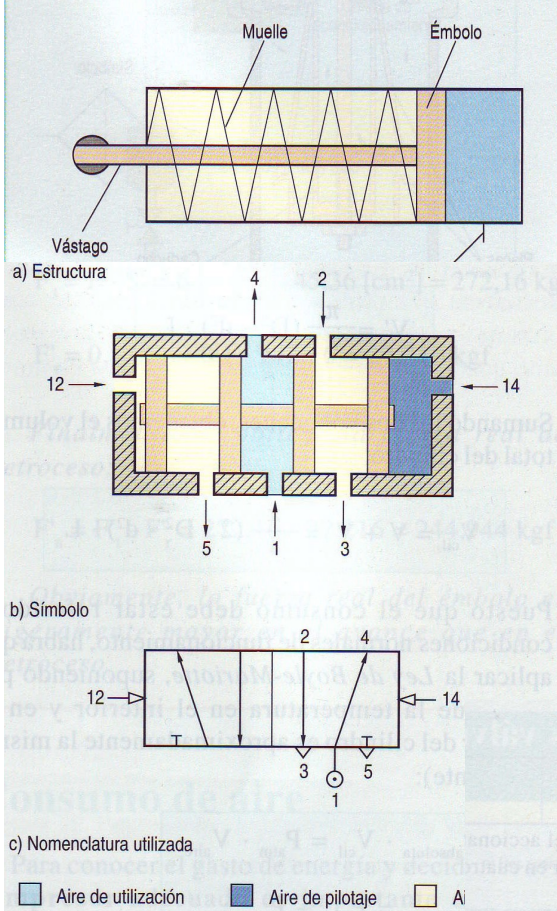

Figura 16.46. Distintas posiciones de un cilindro de doble efecto.

Figura 16.48. Distintas posiciones de un cilindro de doble efecto.